

CHIAYO

SDR-8200M IrDA SDR-8100M IrDA

UHF 2-Way Sync True Diversity /
Diversity Receiver Module



9001:2015

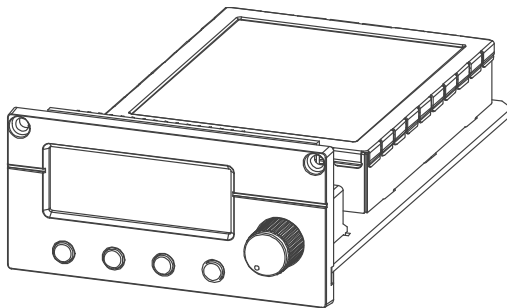

Parts and functions

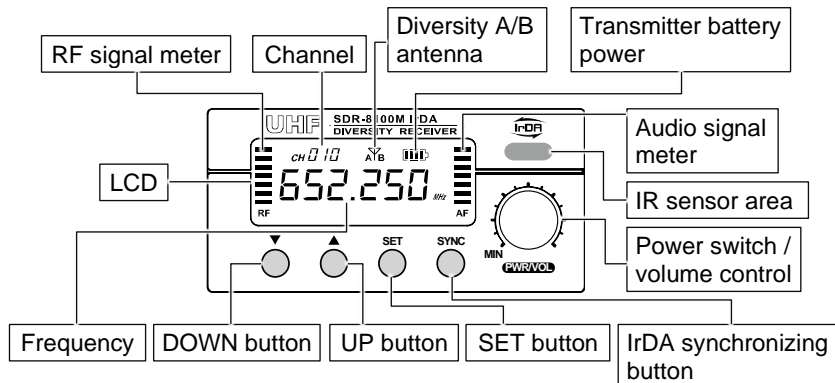

First turn on the power and the LCD display will show last stored channel and frequency. Select a channel that corresponds to the transmitter. When transmitter is turned on, the A/B diversity antenna will appear to denote that it is connected.

Channel synchronizing of the receiver and transmitter

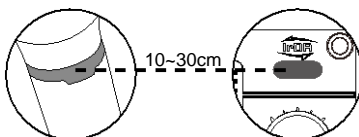

Align infrared areas of the receiver and transmitter within 10~30cm.

Changing receiver's channel

- 1 Press the synchronizing button of the transmitter.

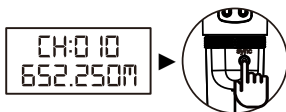

- 2 The transmitter's LED will glow to denote synchronizing signal transmitted.



- 3 The channel number on the receiver's LED will become the same as the transmitter's, which means the receiver has been successfully synchronized.

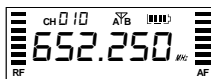

Changing transmitter's channel

- 1 Press the SYNC button of the receiver.

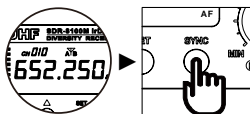

- 2 The transmitter's LED will glow to denote synchronizing signal received.



- 3 The channel number on the transmitter's LCD will become the same as the receiver's, which means the transmitter has been successfully synchronized.



If it doesn't work check that you have the IR sensor panels aligned, that they are facing each other, devices are within 10~30cm of each other, and try again.

CHANNEL scanning

For an interference-free operation, a cleaner channel might be necessary if the current one receives too much interference. To operate the scanning:

- 1 Press ▲(up) or ▼(down) button to make the frequency icon **FREQ** appear on the bottom.

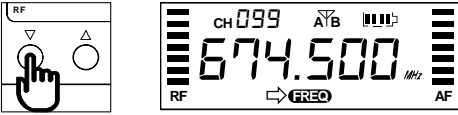

- 2 Hold **SET** button until this icon **FREQ** flashes to denote readiness for setting.

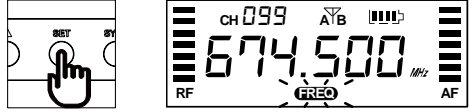

- 3 Press ▲(up) or ▼(down) button to find and locate a clear, interference-free channel.

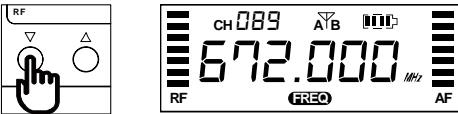

- 4 After a channel is chosen, press **SET** button or wait 5 seconds to store the setting.

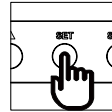

SQUELCH (SQ) setting

When interference is encountered try reducing the sensitivity of the receiver, thus less susceptible to interference. To operate the squelch setting:

- 1 Press ▲(up) or ▼(down) button to turn to the squelch setting page.



- 2 Hold **SET** button until this icon **SQ** flashes to denote readiness for setting.

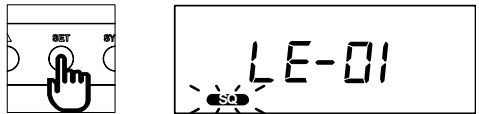

- 3 Press ▲(up) or ▼(down) button to select a new squelch level between 1 and 10.



- 4 After a level is chosen, press **SET** button or wait 5 seconds to store the setting.

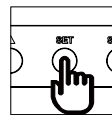

Since increasing the squelch level will also reduce the reception distance, it's recommended to choose the lowest level that can eliminate the interference.

If this still does not solve the problem it means this frequency is not suitable. Adjust the squelch back to its default level and use the scan function to locate a clear, interference-free channel.

CHIAYO ELECTRONICS CO., LTD.

Http://www.chiayo.com.tw | Email: sales@chiayo.com.tw
Office: 30, Lane 27, Section 4, Jen-Ai Road, Taipei 10685, Taiwan
Tel: 886-2-27415741 | Fax: 886-2-27525242
Factory: 88, Chung-Hsiao Street 2, Chiayi 60080, Taiwan
Tel: 886-5-2711000 | Fax: 886-5-5767611



1211415